

# Chest type display freezers



A superbly styled, efficient  
freezer range in 4 sizes



SD-158



SD-298A  
SD-368B  
SD-518B



Attractive curved edges protected by strong plastic mouldings



Control panel with adjustable temperature



Low maintenance condenser (fan assisted) plus skin condenser for maximum efficiency

## Features

- Back of cabinet free from unsightly grilles
- Convenient drain hole and plug for defrost water
- Control panel with adjustable temperature
- Sliding glass lids with lock standard
- Attractive curved edges protected by strong plastic mouldings
- Curved easy-slide lids with handle grip
- Low maintenance condenser (fan assisted) plus skin condenser for maximum efficiency
- Baskets are included

## Optional Features

- Baskets with movable centre divider section
- Castors with brakes front and rear
- Four sides of branding
- Anti-mouse cable
- RFID



Curved easy-slide lids with handle grip



Convenient drain hole and plug for defrost water



Curved easy-slide lids with handle grip



Sliding glass lids with lock standard

### GreenSense Features: Saving Energy and Reducing Lifetime Costs

**Low E Glass Lids**  
Provide insulation effect of triple glazing and reduced possibility of condensation

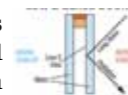

**High Efficiency Compressor**  
Better CoP gives reduced energy consumption. Leading Brand



**Hydrocarbon Natural Refrigerant**  
More efficient. Zero ODP (Ozone Depletion) Negligible GWP (Global Warming Potential)



**Up to 35% savings in annual running costs**

## Optional Features



German brand fan motors for technical superiority



LED temperature display



Castors with brakes front and rear



LED interior lighting

SD-158  
SD-298A  
SD-368B  
SD-518B

# Chest type display freezers

Dimensions		SD-158	SD-298A	SD-368B	SD-518B
External Dimensions	(WxDxH)mm	600x695x920	1000x695x890	1200x695x890	1600x695x890
Packaging Dimensions	(WxDxH)mm	670x760x960	1085x770x960	1285x770x960	1685x770x960
Packaging Quantity (20')		48	30	26	20
Packaging Quantity (20')		102	66	54	42
Packaging Quantity (20')		102	66	54	42

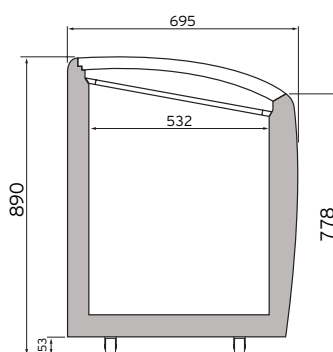
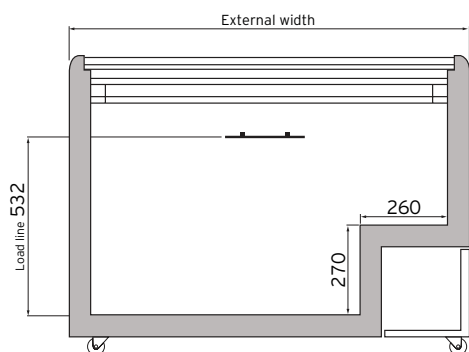

Illustrations refer to SD-298A, SD-368B and SD-518B

Model Technical Data		SD-158	SD-298A	SD-368B	SD-518B
Gross Volume	Ltr	158	298	368	518
Net Volume	Ltr	116	210	265	380
Gross Weight	Kg	45	69	78	90
Net Weight	Kg	38	60	68	78
Baskets Number	EA	2	4	5	7
Climate Class	Class (Max Temp, Relative Humidity)	7 (35°C, 75RH)	7 (35°C, 75RH)	7 (35°C, 75RH)	7 (35°C, 75RH)
Temperature Range	°C	-14 to -23	-14 to -23	-14 to -23	-14 to -23

Electrical Data		SD-158	SD-298A	SD-368B	SD-518B
Voltage/Frequency		220-240V/50Hz	220-240V/50Hz	220-240V/50Hz	220-240V/50Hz
Rated Power (W)	W	140	200	260	300
Rated Electric Current	A	1.4	1.8	1.9	3.0
Energy Consumption (25°C)	kWh/24h	1.6	2.8	3.0	4.2

Refrigeration Data		SD-158	SD-298A	SD-368B	SD-518B
Refrigerant	/	R600a	R134a	R134a	R404a
Optional Refrigerant	/	R134a	R290	R290	R290
Foaming Agent	/	Cyclopentane	Cyclopentane	Cyclopentane	Cyclopentane

Staycold Export Ltd  
9 Hunters Walk, Canal Street  
Chester, CH1 4EB, United Kingdom

tel 01244 321320 fax 01244 322345  
international tel +44 1244 321320  
email [sales@staycold.co.uk](mailto:sales@staycold.co.uk) [www.staycold.co.uk](http://www.staycold.co.uk)



In the interests of continuous product development specifications may be changed without notice.